

TOM — KIRK LIGHTING

Ring Chandelier

The magnificent five-tier Ring Chandelier combines a mesmerising arrangement of light and pattern. This special light is available in four different diameters ranging from 750mm to 1500mm. Strong, graceful and unique, it is designed to be the focal point of a room – commanding attention and creating a lasting impression.

Sizes

750mm Ø
900mm Ø
1000mm Ø
1500mm Ø



Ring Chandelier

Ring Chandelier 1000mm Ø

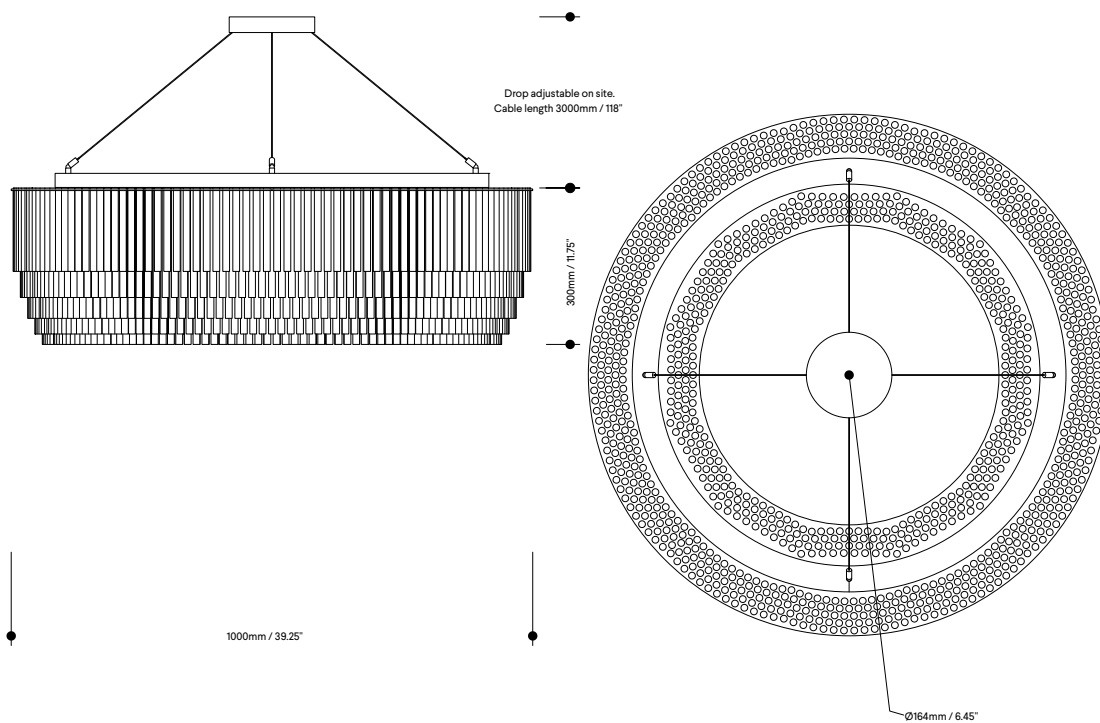

Lamp specifications UK
220-240v 50Hz 12 x 3w G9 LED

Lamp specifications USA
120v 60Hz 12 x 4.5w G9 Type T LED

Luminous flux / CCT
UK – 3000lm 2700K
US – 4800lm 2700K

Dimmable
Yes

Level of protection
IP20

Product weight
42.9–47.6kg / 94.6–105lb

Materials
Borosilicate glass and electroplated
or powder-coated frame

HS code
9405105000

Standards



Metal finishes



Powder-coated



Polished chrome

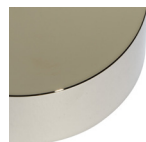

Polished nickel



Brushed brass



Brass-based bronze

Ring Chandelier 1500mm Ø

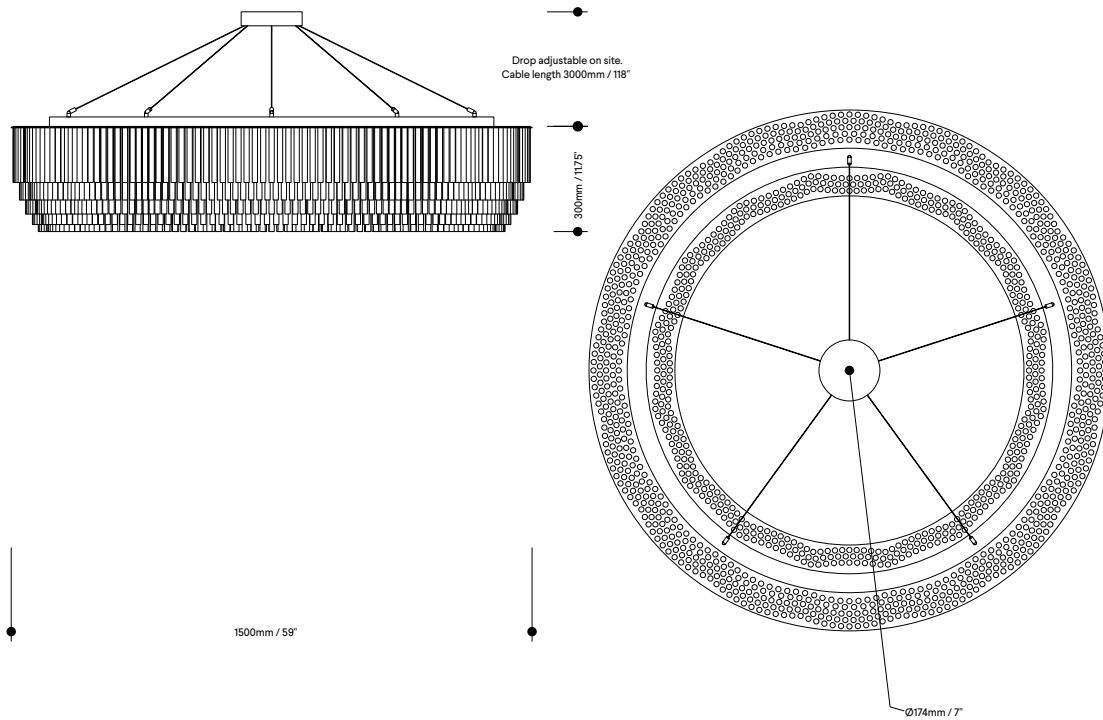

Lamp specifications UK
220-240v 50Hz 16 x 3w G9 LED

Lamp specifications USA
120v 60Hz 16 x 4.5w G9 Type T LED

Luminous flux / CCT
UK – 4000lm 2700K
US – 6400lm 2700K

Dimmable
Yes

Level of protection
IP20

Product weight
59–67kg / 130–147.7lb

Materials
Borosilicate glass and electroplated
or powder-coated frame

HS code
9405105000

Standards



Metal finishes



Powder-coated



Polished chrome



Polished nickel



Brushed brass



Brass-based bronze

